

INSTALLATION of HARVEST AIR FOIL CHAFFER or HARVEST PLASTIC LOUVERED ADJUSTABLE CHAFFER in CASE IH 1680 LONG SHOE, 2188 or 2388 COMBINE

FACTORY SET-UP FOR SUPPORT BRACKET

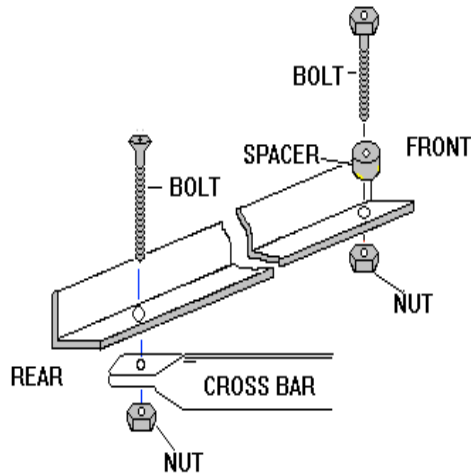

NEW SET-UP FOR SUPPORT BRACKET

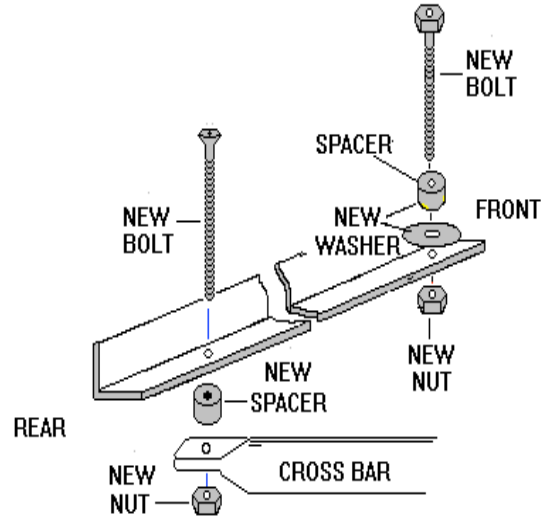

1. Bolts and spacers are provided for both the left and right support brackets. This allows clearance for the **Chaffer** to be installed. With the **Air Foil Chaffer** constructed in one solid piece it is not necessary to use the cross bars for shoe rigidity, although with the cross bar in place it makes the installation of the **Air Foil Chaffer** easier (especially, when working by yourself).

2. Locate the front mounting angle irons that hold the chaffer in place. Remove the nut and install a 3/8" washer under the spacer that is already there. Reinstall the chaffer. Use at least Grade V (preferably Grade VIII) bolt and lock nut. This will give 1 1/4" clearance. The chaffer will slide in and out much easier. Check that the 1 1/4" will be enough to allow the chaffer to slide in and out easily.