

# HARVEST FAN THROAT KIT FOR CASE IH ROTARY COMBINES

## PROBLEM:

1. Dirty sample in the tank, overloaded return, and grain loss.
2. Grain and chaff fall off the back of the chaffer in bunches.

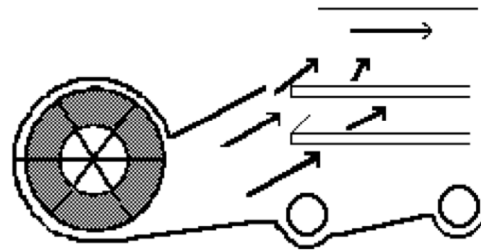
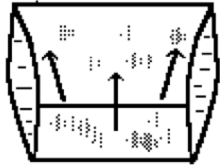

## REASON:

The fan is starved for air in the center, so the middle section of the chaffer has a severe downdraft. Chaff is sucked into the clean grain system. Air escapes over the front of the top chaffer reducing the effective lift at the front of the chaffer. The air strikes the bottom of the grain pan, turns horizontal and blows over the top of the chaffer. The fan throat flares out to the sides contributing to the dead spot in the middle of the chaffer and the stronger flow of air along both sides. Increasing the fan speed blows too much grain in the return, eventually plugging the return. The dirty sample remains. In addition the cleaning sieve [bottom sieve] is far too long and on every forward stroke it cuts the air off to the top chaffer. Also, too much air under the bottom sieve blows clean grain into the return overloading the system.

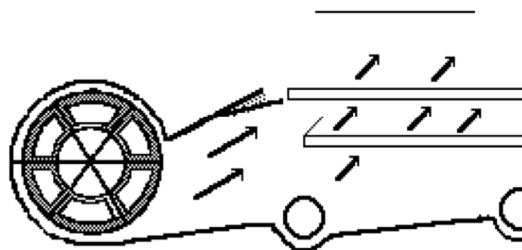
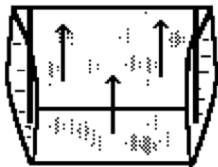

## SOLUTION:

### THROAT TIN

The new Throat Tin eliminates air loss at the front of the chaffer resulting in more effective lift.

### GUIDE VANES

The guide vanes in the new throat tin direct the air equally under the chaffer. The guide vanes reduce the grain blow-over on the outer edges of the chaffer and the dead spot in the center of the chaffer which causes a dirty sample.

### OPEN END DIVIDERS

The open end dividers allow the center of the fan to breathe.

### BOTTOM CLEANING SIEVE

The cleaning sieve should be shortened. This will not cause any problems because there is no grain falling on the front 6" of the bottom sieve. With less air under the bottom sieve, there will be a reduction in the amount of clean grain blown into the return and the front 1/3 of the top chaffer will now receive an even supply of air.

## INSTALLATION of HARVEST FAN THROAT KIT for CASE IH ROTARY COMBINES

### PARTS INCLUDED IN KIT

- 1 TOP THROAT TIN
- 5 BOLT SPACERS [3 ON 40&60 SERIES]
- 5 BOLTS 5/16"x 2" [3 ON 40&60 SERIES]
- 1 CROSS BAR
- 21 TEK SCREWS
- 2 GUIDE VANES
- 12 OPEN ENDED DIVIDERS

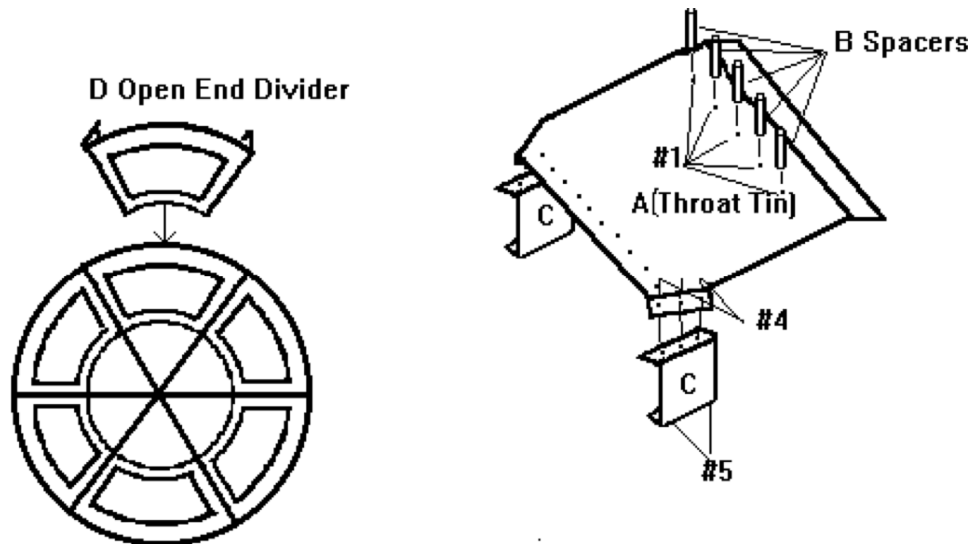

### ASSEMBLY INSTRUCTIONS

Remove top and bottom sieve before installing the Harvest Fan Throat Kit

**NOTE: Install dividers before installing new fan throat.**

#### 1. INSTALLATION OF DIVIDERS [New dividers have 3/8" holes for easier assembly]

- Loosen center spoke bolts. **DO NOT REMOVE**
- Loosen divider bolts on the left end of fan. **DO NOT REMOVE**
- Remove dividers on the right hand end of fan. Replace dividers. [Make sure new dividers are pointed in the same direction as the old ones. Early models with angle iron need to be reversed.]
- Replace old dividers at left end with new ones. Install all bolts finger tight.
- Once dividers are in place, tighten bolts beginning farthest from the main shaft moving to the other end of the fan. Proceed in toward the center of the shaft with the tightening of bolts. Tighten the bolts with a cross hatch sequence as you would tighten a truck wheel. Tighten all bolts and equal amount.

#### 2. INSTALLATION OF FAN THROAT

- Place top throat tin [A] at the top of the fan opening.
- Align holes [#1] with bolt. Use Tek screws to secure the front of the throat [#2] and tighten
- Place guide vanes in throat, line up holes [at#4] and tighten Tek screws. Holes should line up and guide vane should point straight back. This installation prevents air from flowing out along the sides of the throat and helps to provide adequate air pressure to the center of the chaffer.
- Tighten the bottom flange of the guide vanes to the bottom fan throat at holes [#5]
- Rotate the fan to ensure clearance. BE CERTAIN THAT THE TOP THROAT TIN WILL NOT CONTACT THE TOP CHAFFER.

**NOTE: CHECK DAILY FOR ANY CHAFF BUILD UP AT THE FRONT OF THE CHAFFER ON THE TOP OF THE NEW EXTENDED FAN THROAT.** Some customers have sprayed foam insulation on top of the new fan throat tin to seal the gap between the old fan throat and the new throat tin.

## **INSTALLATION of HARVEST FAN THROAT KIT for CASE IH ROTARY COMBINES**

### **3. SHORTENING OF THE BOTTOM CLEANING SIEVE**

You have two choices when shortening the bottom sieve.

{1} Leave the frame and dividers intact and just remove the first 5 rows of louvers. The air flow will be slightly reduced and somewhat disrupted.

{2} The **preferred** method is to remove the front cross bar of the sieve. If you choose to do this please follow the instructions below. Notice the new cross bar has two 6 " long stubs welded to it. These stubs will reinforce the side frames of the sieve. **Exercise extreme caution when cutting and welding the new sieve cross bar into position. We can not warranty any of this sieve work that is not done in our shop.**

- Close the louvers on the bottom cleaning sieve.

- Remove the first five\* rows of louvers and dividers from the bottom cleaning sieve. ***On all 1400 and early 1600 series, be sure to cover the extension fingers at the rear of the grain pan with a 4 1/4" wide plate. (Available from your Case IH dealer) This plate has been factory installed on the late 1600 series machines (after 1989). Failure to do this may cause a dirty sample when using an adjustable long tooth top chaffer. If you are using a Harvest Air Foil Chaffer, this will not be a problem, as you can install a Ripple Tin on the front of the chaffer, covering the front 10" of the chaffer. This prevents any material from falling through at all. If you are going to use an adjustable long tooth chaffer, without installing the 4 1/4" plate over the fingers, then remove only the first three\* louvers from the front of the bottom cleaning sieve.***

-Weld the cross bar [1 1/4" Square Tubing] at the front of the newly shortened dividers. Ensure that you do not cut the dividers too short. If you do you will not be able to close the bottom sieve, as the new front cross bar will interfere with the movement of the louvers in the 6th row.

- On the original front cross bar cut all but 4" on each end. This 4" section is necessary so that the bottom sieve may be reinstalled into the shoe the same way as before.

LEAVE 4" LONG

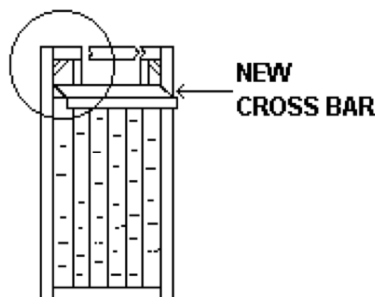
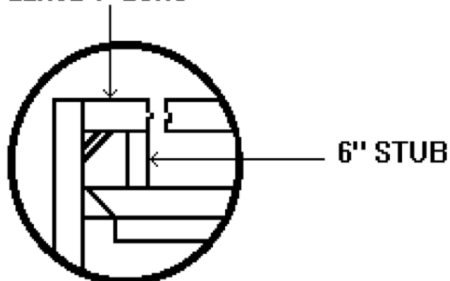

### **4. FRONT CHANNEL SUPPORT FOR THE BOTTOM SIEVE**

- Remove the Front Channel Support and Deflection Plate because it restricts the air.

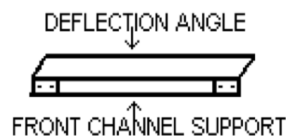

5. Replace the bottom sieve and top chaffer.

6. Have someone turn the machine over by hand while you watch the chaffer move back and forth. Be sure the chaffer does not bump the new throat tin. **Severe damage can result if the chaffer bumps the rear of the throat tin.**